

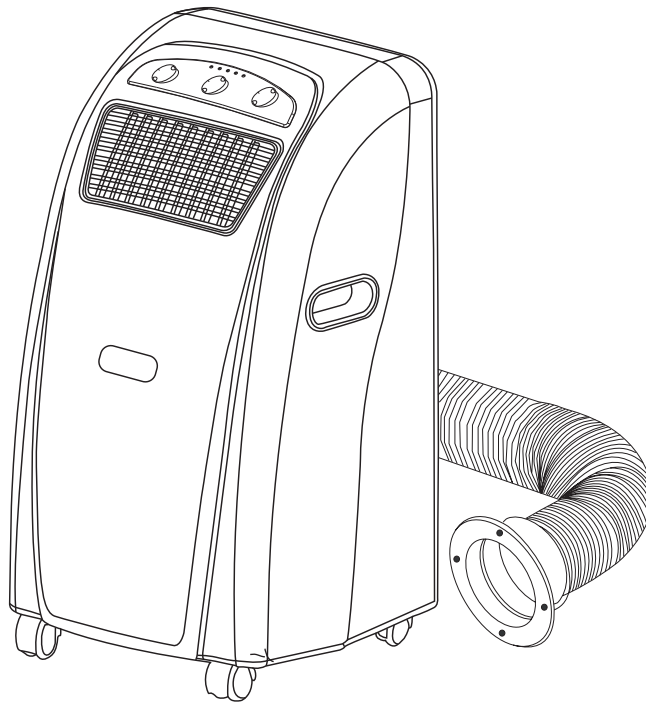

**Mobile Air Conditioner
Instruction Manual
Model TC-N9KM**



**Please read and retain these
instructions for future reference**

SPECIFICATION

Model no.	TC-N9KM
Cooling capacity	8500 BTU 2490 W
Power/Ampere consumption for cooling*	830W/ 3.7A
Air volume (max. speed)	350 m ³ /h
Humidity removal capacity	1.2 L/hr
Power supply	220-240V~, 50Hz
Compressor	Rotary
Refrigerant	R410a
Fan speed	2
Timer	Mechanical switch 1 – 8 hours
Working temperature	Cooling 18 - 32°C
Net Weight	30 kg
Dimension	400 x 377 x 750mm (WxDxH)

PLEASE NOTE:

The data marked with '*' may vary for technical reason, for actual data please refer to the rating label placed at the back of the unit.

Please note: Due to continuous research and development the specifications are subject to change without notice.

BEFORE USE

Important Safety Instructions

1. Transport & store the unit in an upright position only. Leave it in an upright position for at least 3 hours before first use.
2. Always place the unit on an even, level surface.
3. An opening in a window or wall is required to accommodate the exhaust hose to expel the hot air.
4. Make sure the unit is connected to an earthed power supply of the correct rating. (Refer to the rating label located at the back of the unit).
5. The unit will cool when the room temperature is between 18°C~32°C depending on the thermostat setting.
6. DO NOT use this unit for functions other than those described in this instruction manual.
7. DO NOT tilt the unit.
8. DO NOT cover or obstruct the appliance's inlet and outlet grilles.
9. Your air conditioner has been designed to be used only in the home, office and similar conditions and should not be used for any other purpose.
10. This unit is for indoor use only.
11. Never unplug the air conditioner while it is working, this could damage the electronic circuits.
12. DO NOT use the appliance in a wet room, such as a bathroom or laundry room to avoid the risk of electrical shocks.
13. Do not bend or crush the warm air exhaust hose.
14. DO NOT sit or place articles on the appliance.
15. DO NOT use the appliance with wet or damp hands.
16. DO NOT let chemical substances come into contact with the appliance.
17. DO NOT use the appliance in the presence of flammable substances or vapours such as alcohol, insecticides, petrol, etc.
18. DO NOT use the plug to start and stop the appliance. ALWAYS use the intended control panel to start and stop the unit.
19. ALWAYS turn off the appliance when it is not in use and remove the mains plug from the socket outlet.
20. ALWAYS turn the unit off and remove the mains plug before cleaning, carrying out maintenance or moving location.
21. Avoid the use of adapter plugs, multiple sockets and /or extension leads. If their use is necessary, ensure they conform to current safety standards.
22. Do not pull the electrical cable or place it near a source of heat: always unroll it completely to avoid dangerous overheating. If the power cord becomes damaged, the service agent or a similarly qualified person must replace it, in order to avoid a hazard.
23. The filter must be used with the product at all times, when removing it for clearing always turn the unit off and unplug the mains plug from the socket.
24. Do not operate the unit with a damaged power cord or plug, after it malfunctions, has been dropped or damaged. If the power cord is damaged it must be replaced by the manufacturer or a qualified service engineer to avoid a hazard.
25. Closely supervise any children and pets when unit is in use
26. Only use in the upright position on a flat level surface and at least 50cm from any objects.

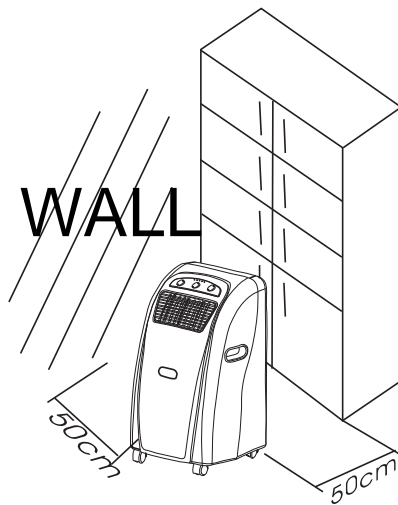

PARTS

Front

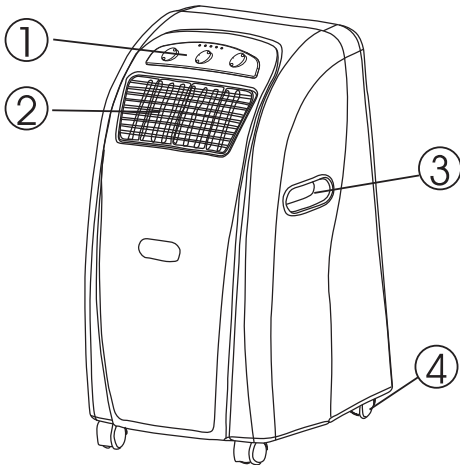

1. Control Panel
2. Air outlet
3. Carry handle
4. Caster

Back

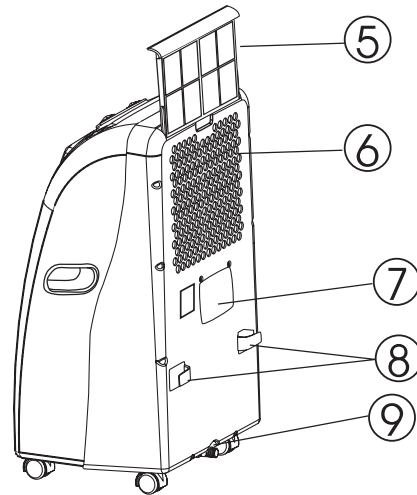

5. Air filter
6. Air inlet
7. Exhaust air outlet
8. Cord storage
9. Water stopper / drainage point

Accessories

10. Indoor adaptor - for insertion over hose and into back of the air conditioner.
11. Outdoor adaptor - for insertion over hose and into foam strip (or into hole in the wall/window).
12. Exhaust hose
13. Foam strip - for filling the open window space and with hole for connection to exhaust hose.
14. Foam strip - for filling the open window space
15. Round cap for filling the hole in wall/window.
16. Drain tube for continuous drainage
17. Water tray
18. Active carbon filter
19. Remote control (for electronic model only)

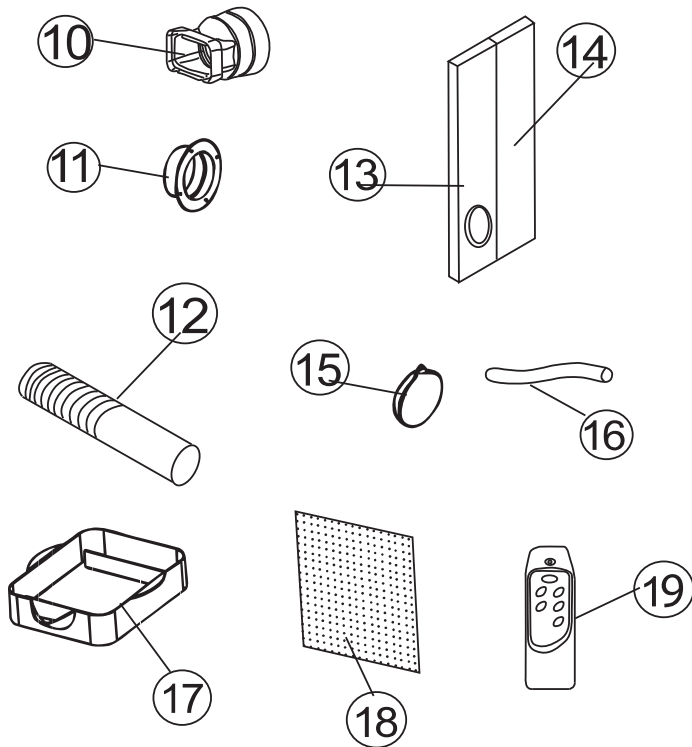

INSTALLATION

Installation of the exhaust pipe

The unit is a portable air conditioner, which can be moved from room to room.

1. Using the foam strips
 - These are not suitable for hinged window systems

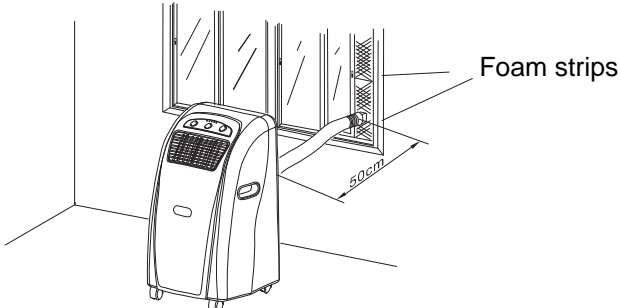

- Place the foam window strips against the window. Mark and cut them to size if necessary.
- Feed exhaust hose through the foam strip and insert strip into window gaps as shown. Slide window across so that foam is held securely. This technique may also be used for sash windows. Note: Please take care to maintain protection against intruders

2. Using the adaptor

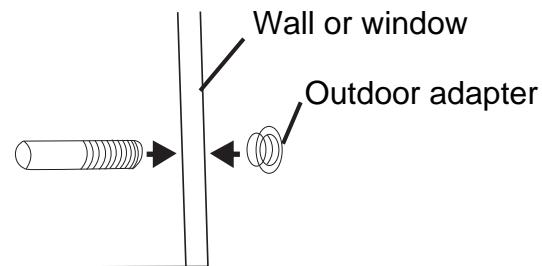
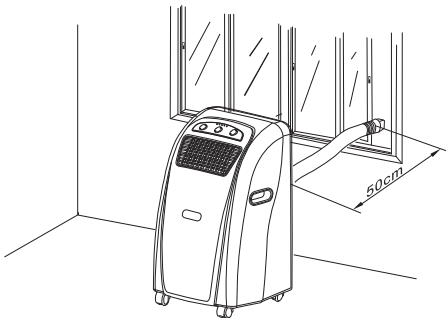

- Cut a 130mm diameter hole in the wall or window, using the appropriate tools and safety equipment.
- Feed exhaust hose through the window or wall and attach the outdoor adaptor from the outside as shown.
- When not in use, cover the hole with the cap (15. on accessories list) provided.

Installing the exhaust hose

- Use only the hose provided and clip exhaust hose and unit adaptor to the back of the air conditioner.
- Avoid kinks and bends in the exhaust hose as this will cause expelled moist air to build up causing the unit to overheat and shut down.

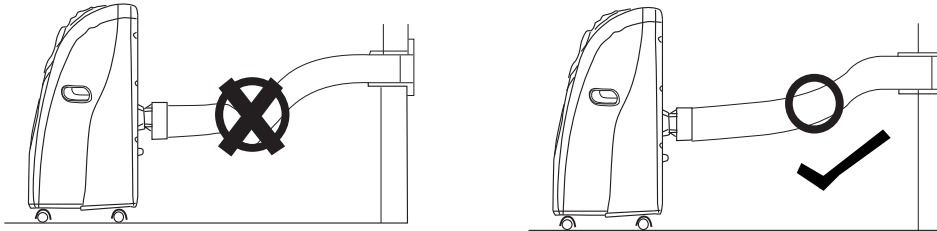

- The hose may be extended from 300mm to 1500mm, but for maximum efficiency use the shortest length possible.

WARNING!

Do not replace or extend the hose as this could cause the unit to malfunction.

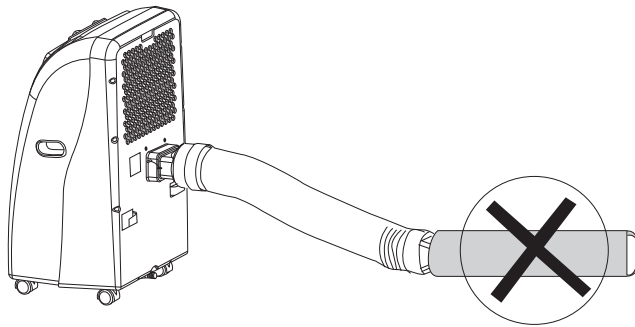

Installation of the carbon filter

1. Remove the filter frame from the unit.
2. Separate the filter fixer from the filter frame.
3. Remove the active carbon filter from its plastic bag.
4. Insert the active carbon filter into the filter frame.
5. Fix the filter by reassembling the fixer onto the filter frame.
6. Re-fit the filter frame inside the unit.

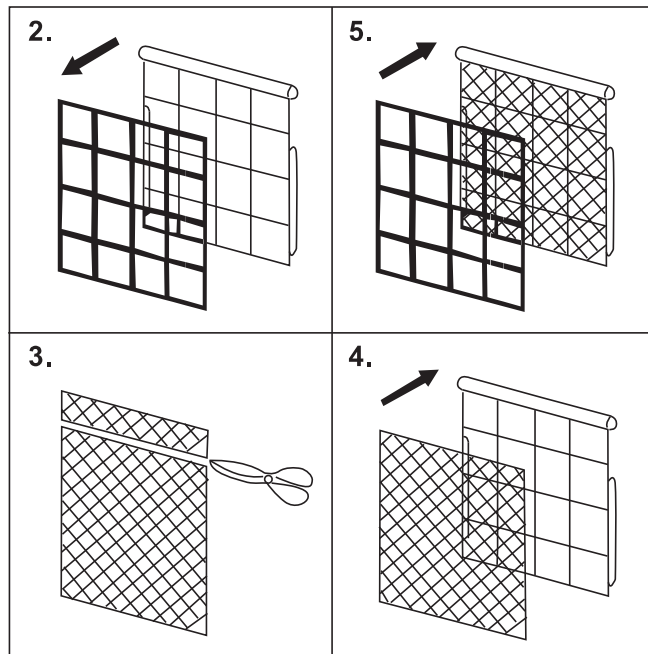
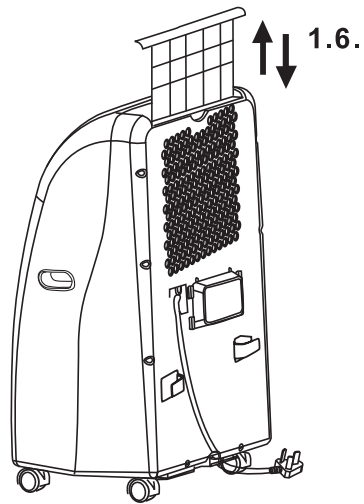

OPERATING INSTRUCTIONS

For Maximum Efficiency

- Close doors and windows.
- Keep curtains and blinds closed during the sunniest part of the day.
- Regularly clean filters.
- Once room has reached the desired conditions, reduce temperature and ventilation settings.

Cooling only model

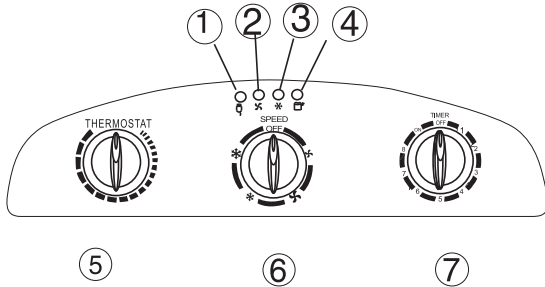

1. Power indicator light
2. Fan operating indicator light
3. Cooling operating indicator light
4. 'Full water' indicator light
5. Thermostat
6. Speed switch with options for - LOW FAN, HIGH FAN, LOW COOL, HIGH COOL
7. Timer (1-8 hours) as well as ON/OFF switch

Turning ON/OFF

Set **TIMER** to ON for continuous operation (the unit will operate as long as it is not turned off). Power indicator light will illuminate
To turn off the unit, turn the **TIMER** to the OFF position.

Setting function / ventilation speed

Cooling only models

Turn the speed switch to select required setting:
LOW FAN, HIGH FAN, LOW COOL, HIGH COOL

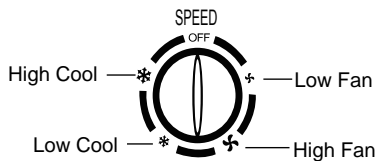

Setting Temperature

Turn the **THERMOSTAT** clockwise to adjust to the temperature required.

Set Timer

Set the **TIMER** to the desired operating time (1 to 8 hours). When the unit finishes the set time it will automatically switch off.

Regulating air flow direction

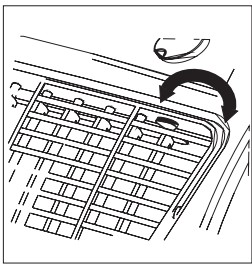

Turn the roller on the air vent to control the air flow direction of the vertical louvers.

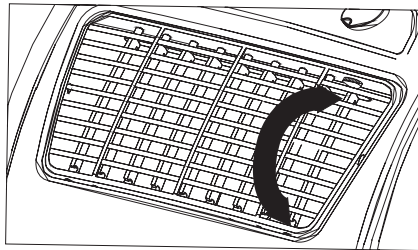

Move the air vent directly to adjust the air flow direction of the horizontal louvers.

NOTE

1. To prolong the life of the unit please wait at least 3 minutes before restarting the unit after it has been switched off.
2. The cooling system will switch off if the ambient temperature is lower than the set temperature. As the ambient temperature rises above the set temperature the cooling function will re-start.

DRAINAGE

During the process of cooling, some water will be extracted from the air into the unit. If the reservoir is full:

On the mechanical model the compressor will stop. The fan will continue to circulate the air. The 'FULL WATER' indicator will illuminate to remind you.

To re-start the unit empty the collected water in one the following ways:

1. Turn off the air conditioner and avoid moving it when full.
2. Position the water tray underneath the drain hole.
3. Remove the with drain cap & rubber plug from the drain hole and allow the water to drain out.
4. When the water tray is almost full, replace the rubber plug in the drain hole and empty the water tray.
5. Repeat until the unit is emptied.
6. Replace the rubber plug and tighten the with drain cap firmly.
7. Switch on the unit - the comp light should not be flashing.

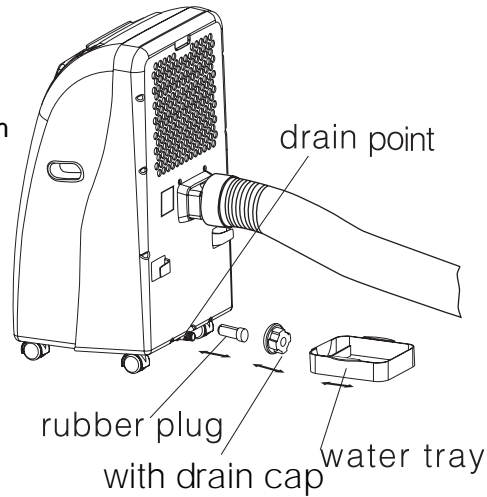

If you wish to operate the unit without the need to empty the water tank, please:

- Remove the with drain cap and rubber plug and retain for future use.
- Connect the drain tube supplied to the water outlet as shown and locate the other end into a drain.
- The drain tube may be extended by adding an extension tube and using a suitable connector, (not supplied by the manufacturer).

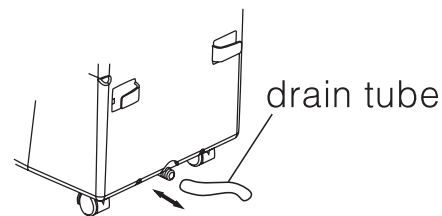
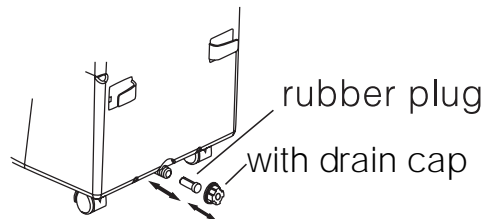

Please note

1. The drain must be at or below the outlet level.
2. Flashing comp / 'full water' indicator will not function in this mode of drainage.
3. If you want to extend the water tube, you can connect it with another tube (OD: 18mm)

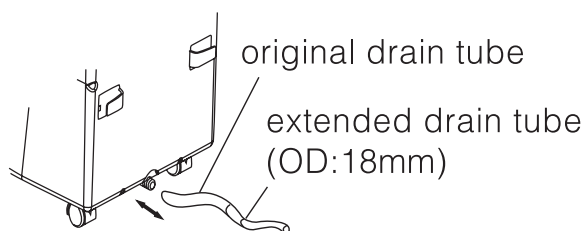

MAINTENANCE

Always switch off and unplug the air conditioner from the mains before cleaning.
To maximize the efficiency of the air conditioner clean regularly.

Cleaning the housing

Use a soft, damp cloth to wipe the body clean.

Never use aggressive chemicals, gasoline, detergents, chemically treated cloths, or other cleansing solutions. These could all damage the unit casing.

Cleaning the filter

Use a vacuum cleaner or tap the filter lightly to remove loose dust and dirt from the filters and then rinse thoroughly under running water (no hotter than 40°C). Dry thoroughly before replacing. Never operate the unit without the filters.

End of season storage

- Drain any water in the unit before completely operating the unit on ventilation only mode for a few hours, to thoroughly dry the inside.
- Clean or change the filter
- Unplug and store the power cord as shown
- Replace in the original carton or cover for storage.

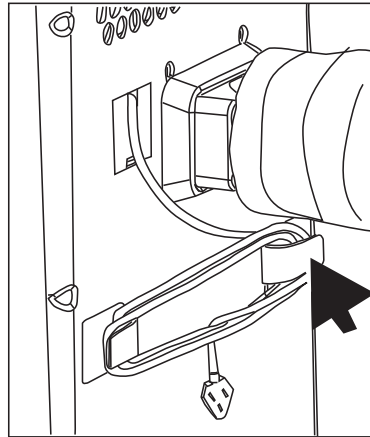

Trouble Shooting

The air conditioner does not run.

- Is the air conditioner plugged in?
- Is there a power failure?
- Is the 'Full Water' indicator flashing?
- Is the room temperature below the set temperature?

The machine seems to have little cooling effect.

- Is there direct sunshine? (Please close the curtains or blinds.)
- Are too many windows or doors open?
- Are there too many people in the room?
- Is there something in the room producing lots of heat?

The machine is not cooling.

- Is the filter dusty, contaminated?
- Is the air intake or output blocked up?
- Is the room temperature below your selected temperature?

Too noisy

- Is the machine positioned unevenly, thus creating vibration?
- Is the floor underneath the machine uneven?

The compressor doesn't run.

- It is possible the overheat protector for the compressor is in operation. Wait for the compressor to cool down.

*** Never try to repair or dismantle the unit yourself**

BS PLUG WIRING

Wiring Instructions: Should it be necessary to change the plug please note the wires in the mains lead are coloured in accordance with the following code :

BLUE - NEUTRAL
BROWN - LIVE
GREEN AND YELLOW - EARTH

As the colours of the wires in the mains lead of this appliance may not correspond with the coloured markings identifying the terminals in your plug, proceed as follows:

1. The **BLUE** wire is the **NEUTRAL** and must be connected to the terminal which is marked with the letter **N** or coloured **BLACK**.
2. The **BROWN** wire is the **LIVE** and must be connected to the terminal which is marked with the letter **L** or coloured **RED**.
3. The **GREEN/YELLOW** is the **EARTH** and must be connected to the terminal which is marked with the letter **E** or \oplus or coloured **GREEN OR GREEN/YELLOW**.
4. Always ensure that the cord grip is positioned and fastened correctly.

If a **13A (BS 1363)** fused plug is used it must be fitted with a **13A (BS 1362)** fuse. If in doubt consult a qualified electrician.

Wiring for a 13 Amp Plug (BS 1363)

Please note. The Earth Terminal is marked with the letter **E** or Earth Symbol \oplus .

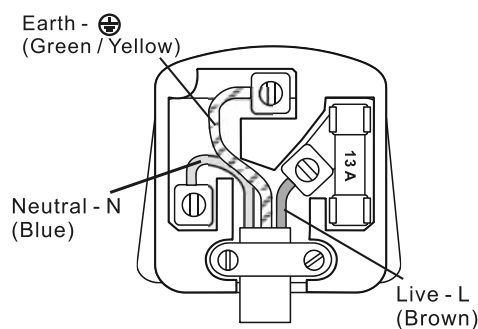

SERVICE & WARRANTY

- Do not operate the unit with a damaged cord or plug, after the unit malfunctions, has been dropped or damaged.
- For your convenience, record the complete model number and product name (located on the Product Identification Plate), the date you purchased the product, and attach your purchase receipt as proof of purchase.
- To ensure your product is covered by warranty, the complete faulty product together with your purchase receipt should be returned to your retailer.

ONE (1) YEAR LIMITED WARRANTY Save This Warranty Information

EHS (International) Ltd. Guarantees this product free from defects in materials and workmanship for a period of one (1) year.

Should this unit be operated under conditions other than those recommended, at voltages other than the voltage indicated on the unit, or any attempts made to service or modify the unit, will render this **WARRANTY VOID**. The product you buy may sometimes differ slightly from illustration. This warranty is in addition to, and does not affect, your statutory rights.

Should you have a problem with this product, please call our Help Desk on:
(0870) 742 5021

This product has been manufactured to comply with EEC Directives 73/23/EEC and 89/336/EEC



Waste electrical products should not be disposed of with household waste. Please recycle where facilities exist. Check with your Local Authority or retailer for recycling advice.



EHS, Manchester, M17 1RN