

V12

Climatizzatore murale con pompa di calore SENZA UNITA' ESTERNA
Wall mounted air conditioner WITHOUT EXTERNAL UNIT
Climatiseur mural avec pompe à chaleur SANS UNITÉ EXTÉRIEURE
Acondicionador mural SIN UNIDAD EXTERNA

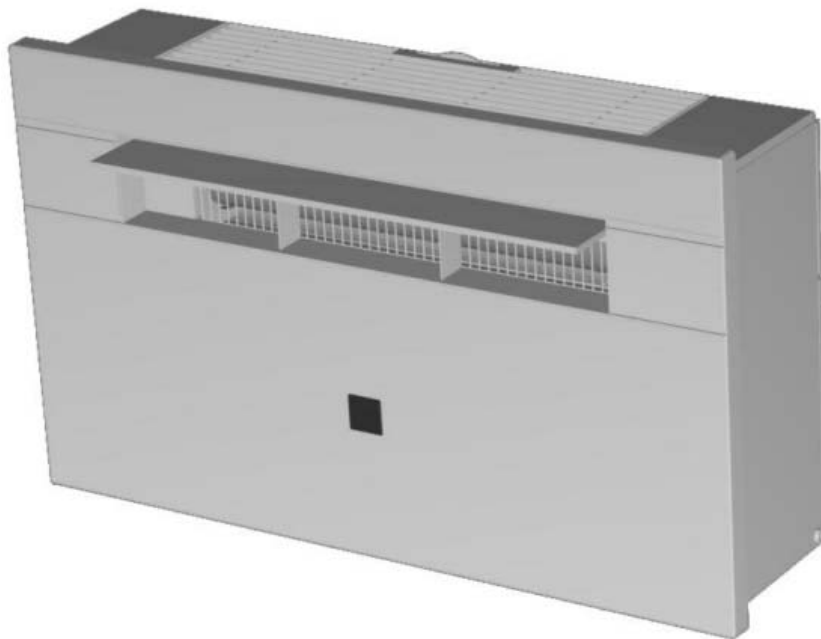

MANUALE D'INSTALLAZIONE ED USO
USER AND INSTALLER MANUAL
MANUEL D'INSTALLATION ET UTILISATION
MANUAL DE INSTALACIÓN Y USO

GNAS

CONTENTS

1. GENERAL INFORMATION

- 1.1 INTRODUCTION
- 1.2 BS PLUG WIRING
- 1.3 IMPORTANT SAFETY INSTRUCTIONS
- 1.4 RECEIVING THE GOODS
- 1.5 HANDLING
- 1.6 PART LIST
- 1.7 TECHNICAL FEATURES

2. INSTALLATION

- 2.1 POSITIONING OF THE AIR CONDITIONER
- 2.2 PAPER TEMPLATE
- 2.3 DRILLING THE WALL
- 2.4 FASTENING THE BRACKET
- 2.5 INSTALLATION OF AIR PIPES AND GRATINGS
- 2.6 FITTING THE GRATINGS
- 2.7 FITTING THE UNIT ON BRACKET
- 2.8 DRAINAGE LINE

3. USE AND MAINTENANCE

- 3.1 REMOTE CONTROL
- 3.2 REMOTE CONTROL FUNCTIONS
- 3.3 INSTRUCTIONS FOR USE WITH REMOTE CONTROL
- 3.4 COOLING FUNCTION
- 3.5 SLEEPING FUNCTION
- 3.6 HEATING FUNCTION
- 3.7 DEHUMIDIFIER FUNCTION
- 3.8 FAN FUNCTION
- 3.9 AUTO MODE
- 3.10 TIMER FUNCTION
- 3.11 MAINTENANCE
- 3.12 PROBLEM SOLVING

1. GENERAL INFORMATION

1.1 INTRODUCTION

PLEASE NOTE.

Do not dispose of any packaging until the installation of the equipment is completed.

After having removed the packing, check that all the content is intact and complete.
(See list of accessories). In the event of missing parts, contact your retailer.

This unit has been designed to cool or heat the air of a room and should only be used for this purpose.

The manufacturer cannot be held liable for damage caused to property or injury to persons or animals due to incorrect installation, regulation and maintenance or improper use.

This air-conditioner contains R410-A refrigerant: at the end of its life, the disposal of this equipment must be in accordance with the strict regulation governing the recycling of this product, please operate with caution during the disposal.

Please contact your local authority for regulatory advice.

Do not switch on before having totally assembled the unit and before installing in its correct operating position.

Before starting the appliance, check that it is correctly earthed, according to the legislation in force in the country concerned.

1.2 BS PLUG WIRING

Wiring Instructions: Should it be necessary to change the plug please note the wires in the mains lead are coloured in accordance with the following code :

BLUE - NEUTRAL
BROWN - LIVE
GREEN AND YELLOW - EARTH

As the colours of the wires in the mains lead of this appliance may not correspond with the coloured markings identifying the terminals in your plug, proceed as follows:

1. The **BLUE** wire is the **NEUTRAL** and must be connected to the terminal which is marked with the letter **N** or coloured **BLACK**.
2. The **BROWN** wire is the **LIVE** and must be connected to the terminal which is marked with the letter **L** or coloured **RED**.
3. The **GREEN/YELLOW** is the **EARTH** and must be connected to the terminal which is marked with the letter **E** or \oplus or coloured **GREEN OR GREEN/YELLOW**.
4. Always ensure that the cord grip is positioned and fastened correctly.

If a **13A (BS 1363)** fused plug is used it must be fitted with a **13A** fuse.
If in doubt consult a qualified electrician.

Wiring for a 13 Amp Plug (BS1363)

Please note.

The Earth Terminal is marked with the letter **E** or Earth Symbol \oplus .

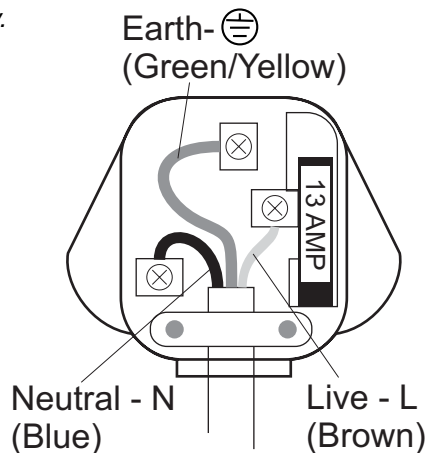

1.3 IMPORTANT SAFETY INSTRUCTIONS

When using electrical appliances, basic safety precautions should always be followed:

1. *Do not place objects on the product or allow objects to obstruct the inlet or outlet openings.*
2. *Extreme care should be taken when any product is used by, or near children and pets, and whenever the product is left operating and unattended.*
3. *Please note: If you are drilling the hole above ground floor level, please ensure that an area has been secured and while the holes are drilled the outside area is supervised, until drilling has been completed.*
4. *Before operating the product remove the unit from its packaging and check it is in good condition.*
5. *Do not let children play with the packaging, for example plastic bags.*
6. *Do not operate any product with a damaged cord or plug, or after the unit malfunctions, has been dropped, or damaged in any manner. Return the unit to an authorised service facility for examination and repair to avoid a hazard.*
7. *Do not attempt to repair or adjust any electrical or mechanical functions on this unit as this may void warranty, contact your service engineer.*
8. *Always operate the product from a power source of the same voltage, frequency and rating as indicated on the product identification plate.*
9. *This unit is not intended for use in wet or damp locations.*
10. *Do not place the unit near an open flame, cooking or heating appliance, or hot surface.*
11. *Do not let the power cord hang over the edge of a table or counter. Arrange the power cord away from an area where it may be tripped over.*
12. *Never place the power cord under a carpet or rug. Do not operate the unit in areas where petrol, paint, or other flammable liquids are used or stored.*
13. *Do not carry out any cleaning or maintenance or access internal parts until the air-conditioner has been disconnected from the mains electricity supply.*
14. *Do not alter the safety or regulating devices without the permission and instructions of the air-conditioner manufacturer.*
15. *Do not pull, remove or twist the electric cable connected to the air-conditioner, even if disconnected from the mains electricity supply.*
16. *Avoid prolonged direct contact with the flow of the air from the unit and the room being closed with no ventilation for a long period of time.*
17. *If the fresh air intake duct is not installed, periodically open the windows to guarantee a correct change of air.*
18. *Repair or maintenance work must be carried out by a service engineer or by qualified technicians in compliance with the instructions given in this booklet. Do not alter the appliance, since hazardous situations could be created while the manufacturer of the appliance will not be liable for any damage or injury caused.*

This instruction booklet is an integral part of the appliance and should therefore be carefully preserved and always accompany the appliance in the event of transfer to another owner or user or another installation engineer.

Should the booklet be damaged or lost, please request an additional.

1.4 RECEIVING THE GOODS

The air-conditioner is delivered in a protective packaging and is accompanied by an instruction manual. This manual is an integral part of the air-conditioner and should therefore be carefully read and preserved. When the unit is unpacked, please check that the equipment and the accessory pack are complete and undamaged.

1.5 HANDLING

- Be fully aware of the weight of the unit before attempting to lift it. Take all necessary precautions to avoid damaging the product or causing personal injury.
- It is advisable to remove the packing only when the air-conditioner has been located in the point of installation.
- Carefully remove the adhesive strips positioned on the air-conditioner.
- Packaging components must be disposed correctly and not left within reach of children, since they are a potential source of danger.

To avoid any possible damages during transportation the unit is provided with compressor holders that must be removed before installing the air conditioner (see 2.6).

1.6 PART LIST

1. FASTENING BRACKET
2. REMOTE CONTROL
3. REMOTE CONTROL HOLDER
4. DRAINAGE PIPE
5. EXTENSION CONDENSATE HOSE
6. PIPE FASTENING INNER FLANGE
7. EXTERNAL GRATING
8. HOT AIR DISCHARGE PIPE (160 mm.)
9. AIR INTAKE PIPE (150 mm.)
10. PAPER TEMPLATE FOR WALL DRILLING
11. KIT OF SCREWS AND CABLE TIE
12. GRATING FIXING CORD
13. INSTRUCTION MANUAL
14. RUBBER PLUG

This product has been manufactured to comply with EEC Directives 73/23/EEC and 89/336/EEC



Waste electrical products should not be disposed of with household waste. Please recycle where facilities exist. Check with your Local Authority or retailer for recycling advice.



Any batteries used in the remote control contain materials, which are hazardous to the environment. They must be removed from the remote control when they reach the end of their life and disposed of responsibly.

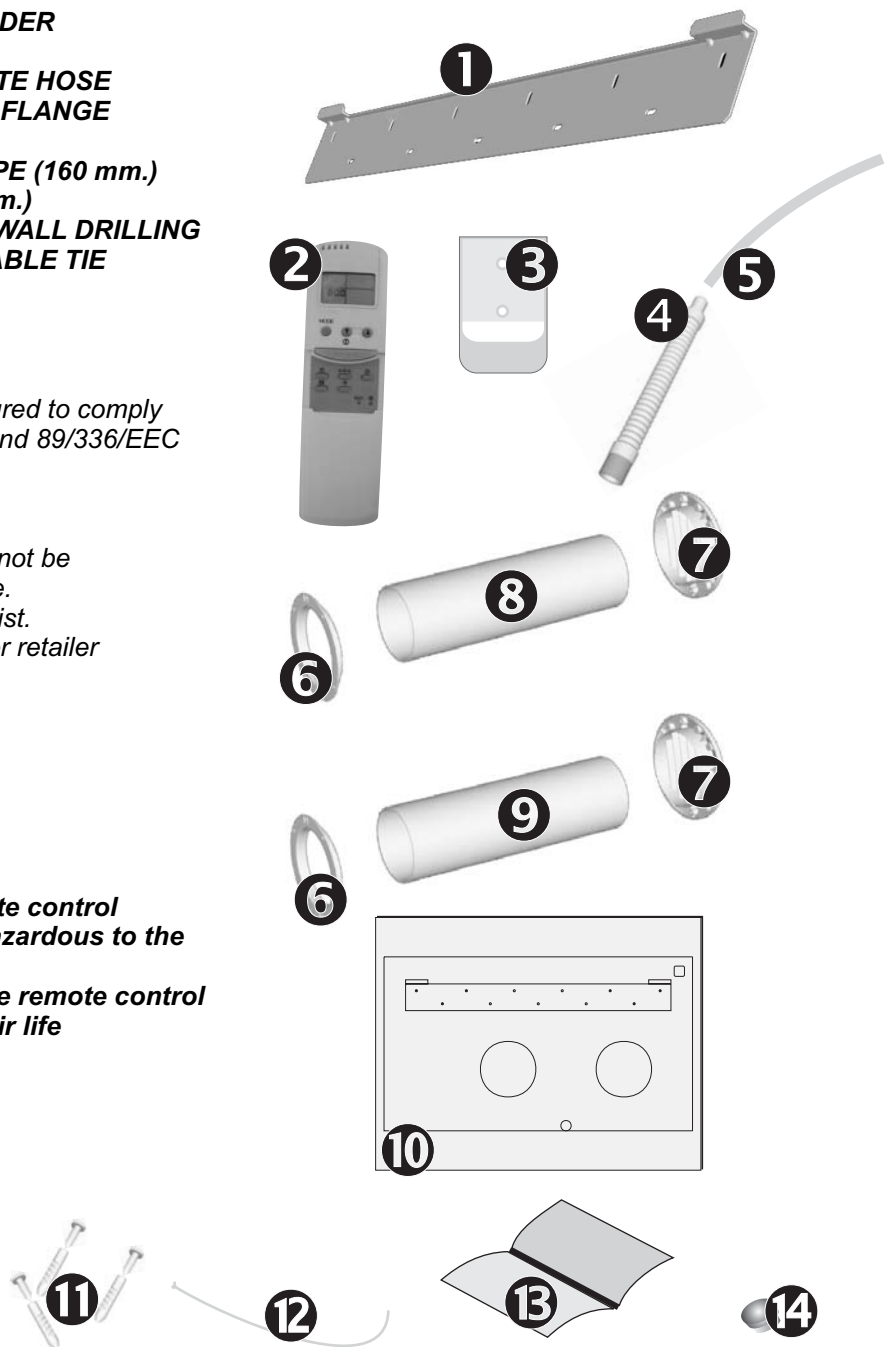

1.7 TECHNICAL FEATURES

| | |
|------------------------------------|----------|
| Model | V12 |
| Cooling capacity * (W) | 2857 |
| Heating capacity * (W) | 2824 |
| Rated voltage (V) | 220-240 |
| Absorbed power in cooling* (W) | 1090 |
| Absorbed current in cooling* (A) | 4,1 |
| Absorbed power in heating* (W) | 960 |
| Absorbed current in heating* (A) | 4,1 |
| Air flow (m ³ /h) | 400 |
| Noise level (dB A) | 38-45 |
| Dehumidification capacity* (l/24h) | 29 |
| Cooling gas | R410A |
| Dimensions H/W/D(cm) | 55/93/24 |
| Weight (Kg) | 45 |

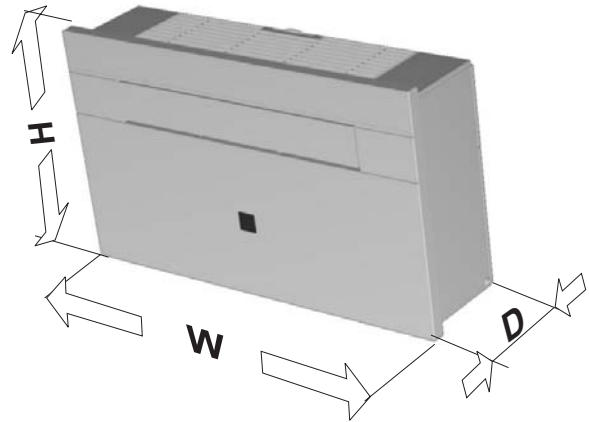

* STANDARD TEST CONDITIONS -EN 14511-

OPERATING CONDITIONS IN COOLING AND DEHUMIDIFICATION MODE

- from 18°C 47% R.H. to 43°C 47% R.H.

OPERATING CONDITIONS IN HEATING MODE

- from -5°C 41% R.H. to 24°C 41% R.H.

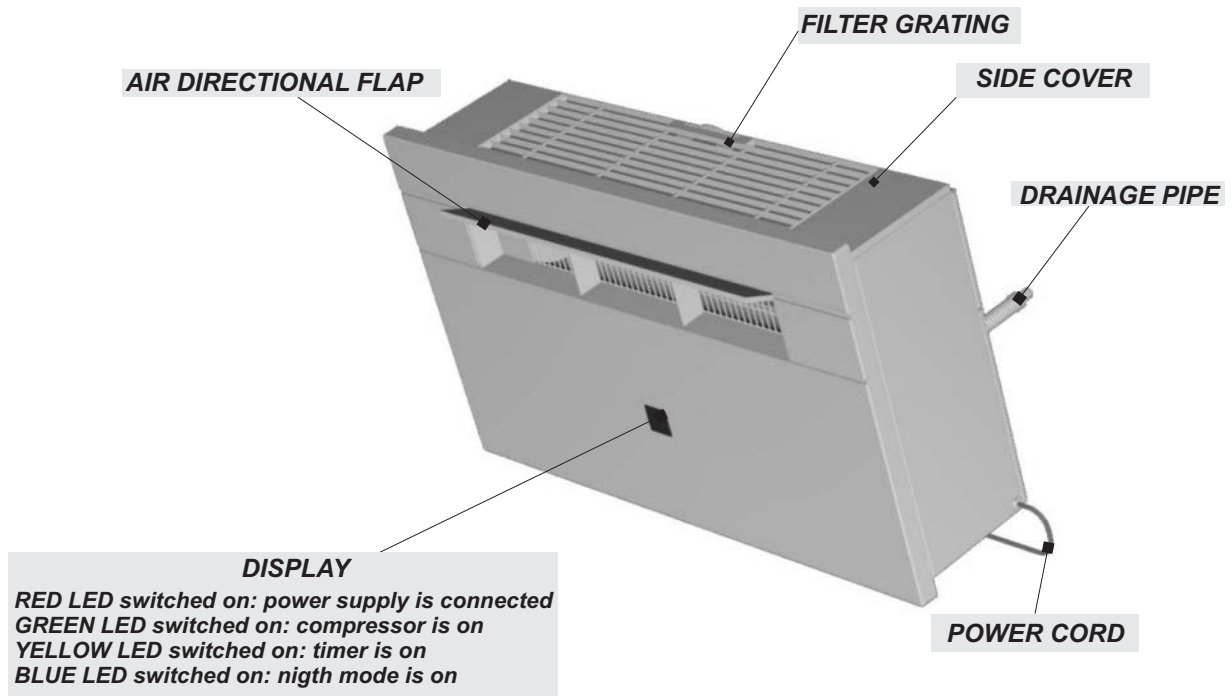

2. INSTALLATION

2.1 POSITIONING THE AIR CONDITIONER

To maintain the best performance from your unit, prevent breakdowns or hazards, you must position it correctly. Please follow the guidelines and instruction below in full, as failure to do so could cause potential installation problems.

- The air conditioner must be installed on an exterior wall that has access to the outside with a minimum of 2 meters clearance to the outside.
There should be no obstacles within the 2 meters, to allow circulation of the airflow.
- The unit must be fitted leaving room all around as illustrated in the paper template.
- The wall on which the unit is installed must be sturdy and able to withstand the weight of the unit.

After determining the best place for installation as described above, please check to ensure that the wall can be drilled in the chosen area without interfering with other structures or installations (beams, piers, pipes, wires, etc.).

Please also ensure that there are no obstacles on the outside of the wall, which may obstruct air circulation through the drilled holes, for example: plants and their leaves, slats or panelling, drain pipes, overflows and gratings, etc.). Any obstruction could interfere with the correct performance of the unit.

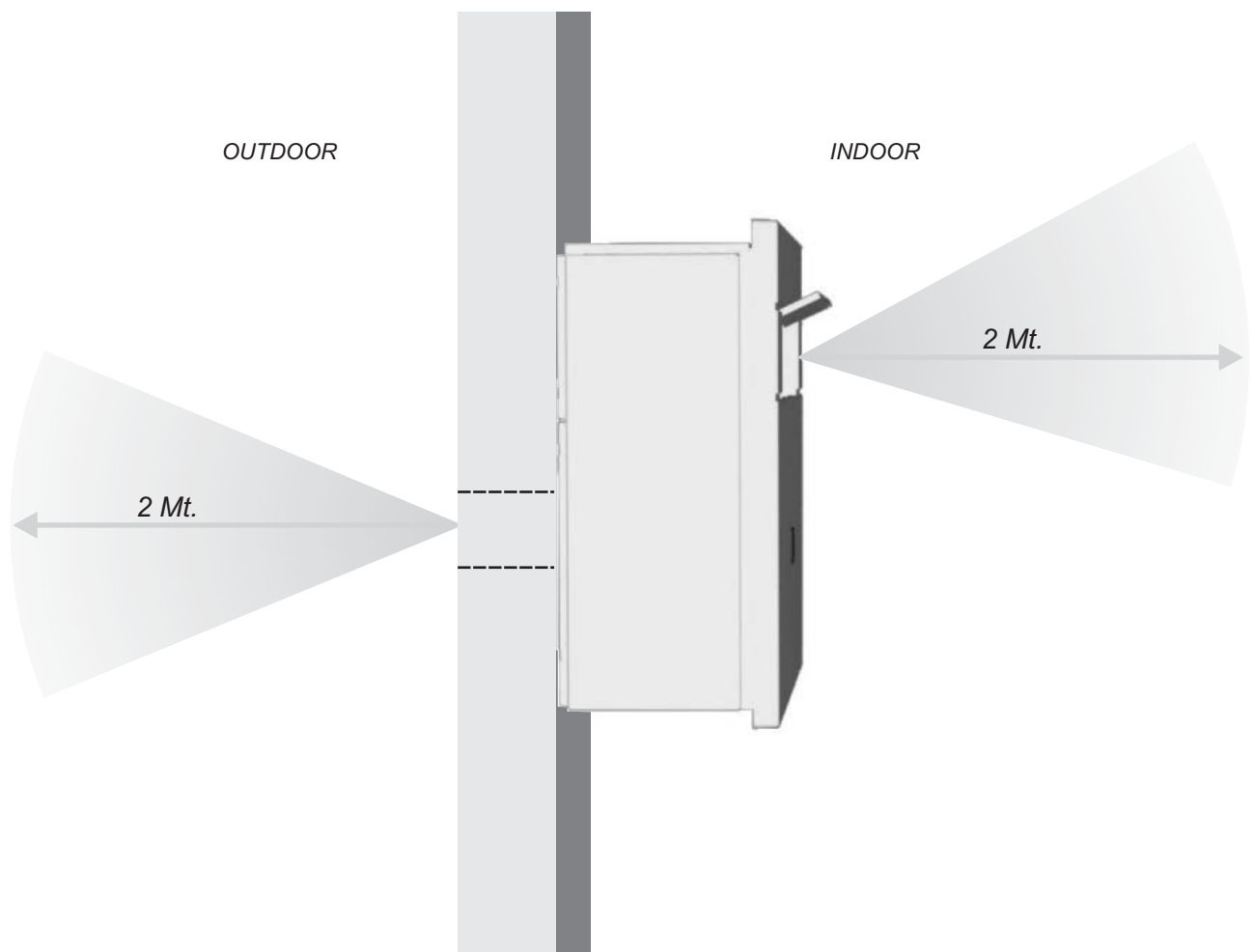

2.2 PAPER TEMPLATE

Fasten the template to the wall once the following guidelines have been thoroughly checked.

- Do not drill any holes until you are 100% confident that there are no obstacles in the area you wish to drill and there are no obstructions, which could be hidden by the construction of the wall, for example: Electrical wiring water & gas pipes or supporting lintels or beams.
- Ensure that a spirit level is used, as the unit must be level.
- Follow the installation instructions & measurements in full.

Paper Template (copy to scale enclosed with accessories)

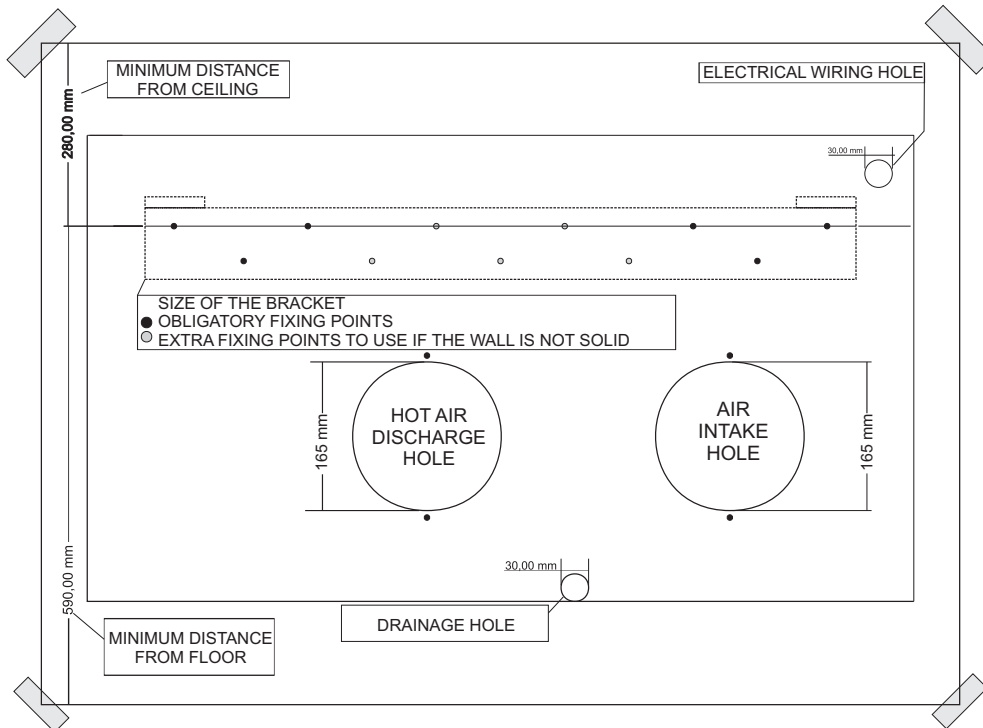

2.3 DRILLING THE WALL

Please note: If you are drilling the hole above ground floor level, please ensure that an area has been secured and while the holes are drilled the outside area is supervised, until drilling has been completed.

INTAKE AND OUTLET HOLES

- This operation should be carried out using the proper tools (diamond tip or core borers drills with high twisting torque and adjustable rotation speed)
- Fasten the template to the wall taking care to check the distance from the floor and or ceiling and keep it horizontal by using a spirit level.
- Use a pilot drill to mark the centre of each core hole to be drilled. Use a core boring head having a diameter of 165 mm to drill the two holes for intake and outlet the air.
- It is recommended that the holes must have a slightly downward inclination of 3-5 degrees to prevent any backflow of water from the pipes.

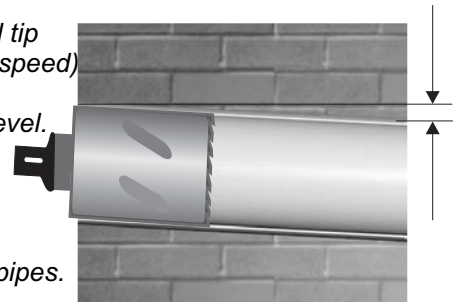

DRAINAGE HOLE

The unit produces condensate that has to be extracted to enable the unit to operate correctly. It is necessary to drill a hole through the wall measuring 30mm in diameter in the position shown in the paper template. Drainage occurs by gravity. For this reason, it is essential for the drain line to have a minimum downward inclination of at least 3% throughout its length.

2.4 FASTENING THE BRACKET

- Drill the holes for anchoring the fastening bracket to the wall using preferably the 6 holes showed in black on the paper template. If the wall is not sturdy enough it is advisable to use extra anchor bolts using the holes showed in grey on the paper template.
- The anchor bolts provided require a 8mm holes; the wall should be inspected to determine if provided bolts are useful or if it is necessary to use a different anchorage. The manufacturer is not liable in case of underestimation of the structural consistency of the anchorage made at the time of installation.

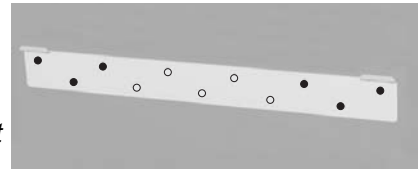

2.5 INSTALLATION OF THE PIPES

- After drilling the holes, the plastic pipes supplied with the air conditioner need to be fitted through them.
 - The pipe with a diameter of 160mm (hot air discharge) and has to be fitted in the left hole. The length of the pipes should be 10 mm less than the depth of the wall. Use a normal hacksaw to cut the supplied pipes to the correct length.
 - The tube diameter is nearly the same as that carried out using the 165 mm nominal diameter core drill therefore you may need to slightly force the introduction of the pipe, using in difficult cases, a normal rubber hammer and a small piece of timber to gently tap the tube into the hole.
 - Fit the plastic pipe into the hole and fasten the flange with 2x6 mm screws and wall plugs.
 - Should the insertion prove to be too difficult, we suggest you drill using the core bit inside the hole so as to widen the internal diameter slightly.
 - Please use the same instructions to fit the right hand tube (air intake pipe) using the supplied pipe with a diameter of 150mm.
- The tube diameter is slightly smaller than that carried out using the 165 mm nominal diameter core drill. Please centre the pipe into the hole in the wall and insulate and seal its perimeter to prevent air and humidity infiltration using polyurethane foam.

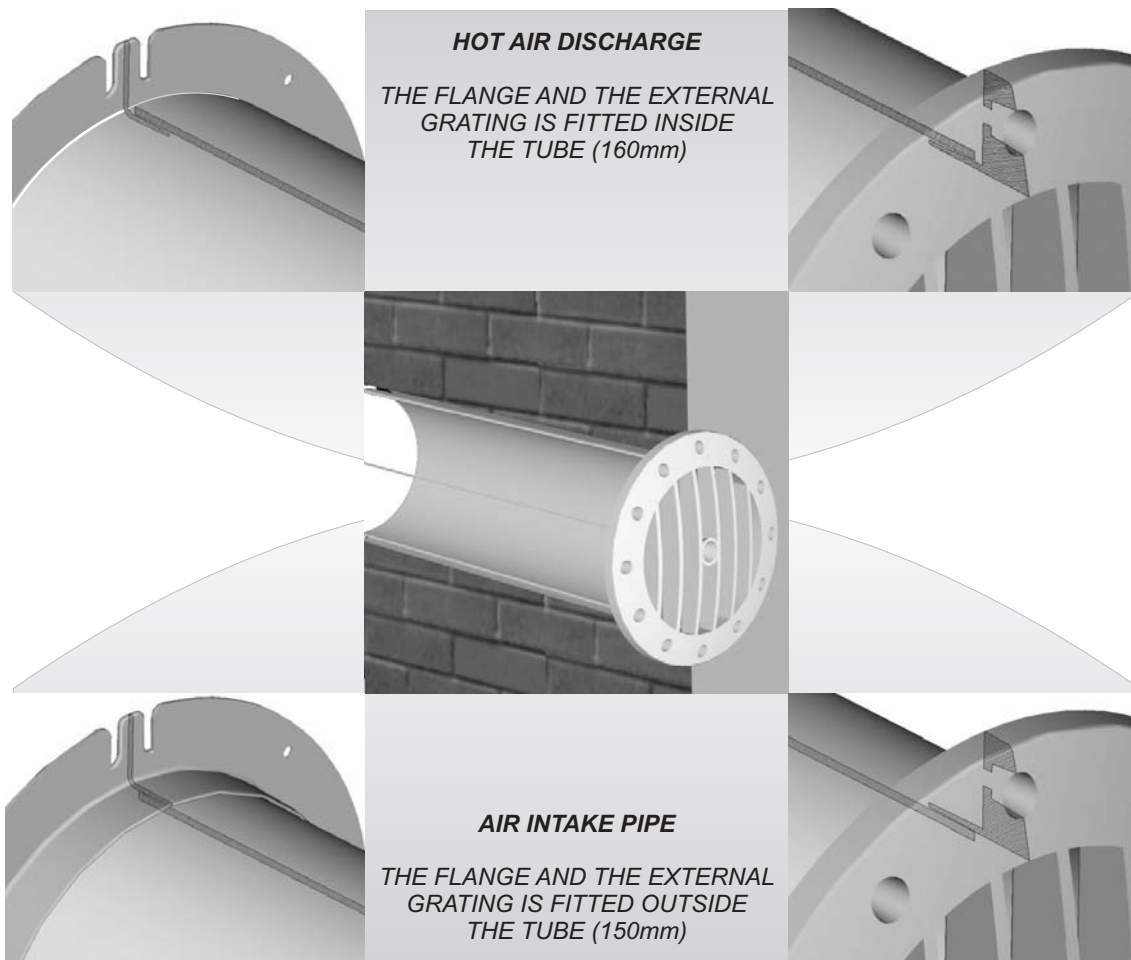

2.6 FITTING THE GRATINGS

To fit the external two gratings please proceed as follows:

Familiarise yourself with the fitting of the grating to the tube, before installation. Insert the cords through the centre of the grating. One grating fits on the outside of the tube and the other fits inside. The air intake is the smaller hole and the grating therefore fits on the outside of the air intake tube.

Insert the supplied cord into the hole.

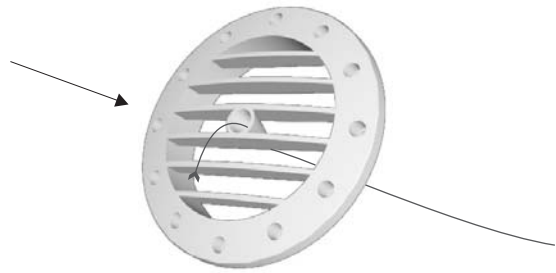

Fold the outer grating in half grasping the cord with your free hand.

Insert your arm inside the pipe with the grating and push all the way to the outside.



Let the grating unfold and pull the cord toward you. One grating fits on the outside of the tube and the other fits inside.

With a little patience and manipulation the 2X gratings will fit the end of the tubes.

Grasping the cord, insert your fingers between the fins and pull the grating toward you until the same is properly slipped in the pipe, keeping the fins in vertical position.



Tighten the cord and fasten it to the dent on the internal flanges.

If the external grating is accessible to prevent its removal, it is recommended to fasten it to the wall with wall plugs and screws with a diameter of 6 mm.

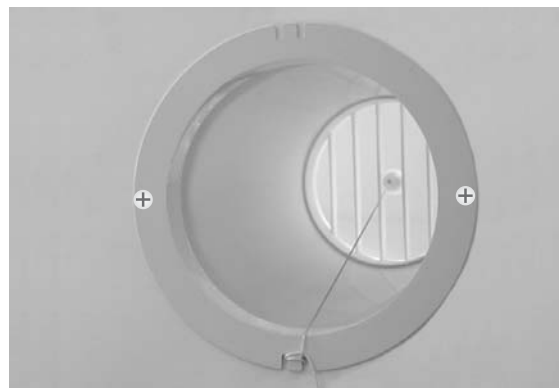

2.7 FITTING THE UNIT ON BRACKET

After checking again that the fastening bracket is secure is securely fastened to the wall, and that any necessary preparations for electric connection and condensate drainage have been made, please remove the compressor holders (remove plastic belt A and unscrew holder B and fasten the air conditioner to its supporting bracket, A and B can be discarded).

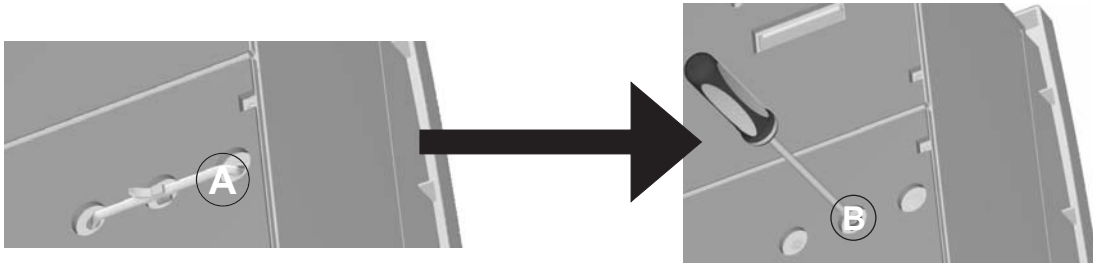

Lift it up by holding the sides at the bottom.

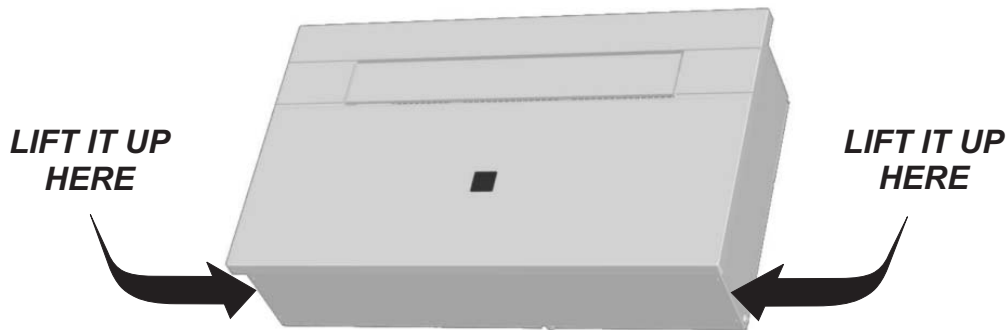

Tilt the unit slightly toward you to facilitate the operation of fastening it to the bracket. The unit is provided with an insulated drainage pipe (450mm long) to fit on the pipe that protrudes from the lower backside of the unit to be inserted in the drainage hole : the drainage must be inserted as described in the section 2.8, through the hole previously drilled in the wall.

The air conditioner can now be pushed firmly against the wall. Inspect carefully the installation to make sure that the insulating back panel must fit firmly against the wall and there are no fissures at the back of the air conditioner.

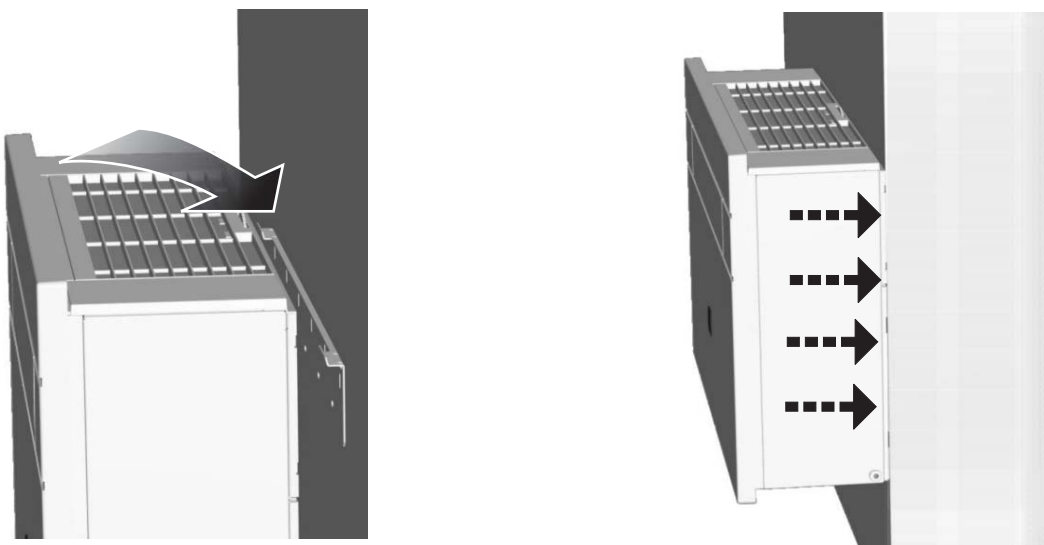

2.8 DRAINAGE LINE

To complete the drainage line fit the drainage on the provided pipe (C). A further extension pipe (D) with an internal diameter of 16 mm can be fitted if necessary.

If the line drains into a vessel (tank or other recipient), this container should not be sealed and the drainpipe should not remain immersed in the water.

Install the extension drain condensate as required. The drain should flow in a downwards direction, as this is a gravity flow (E).

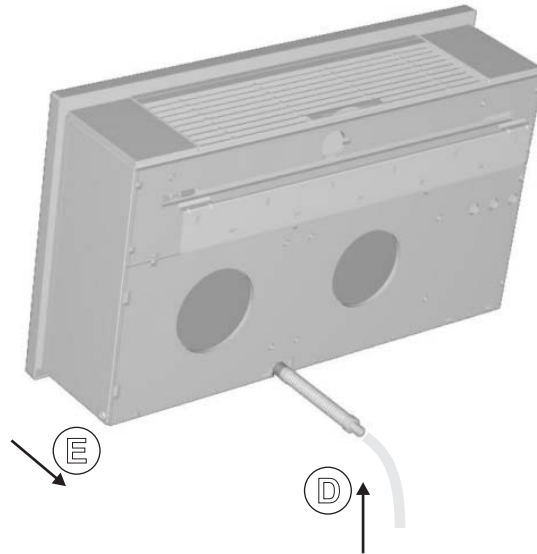
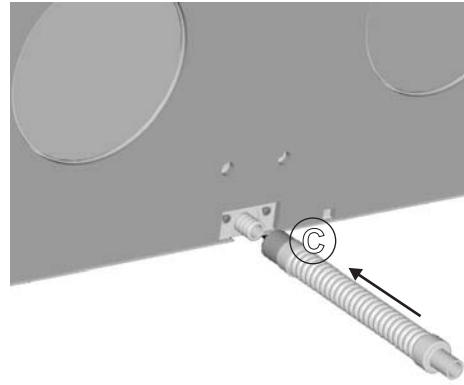

3. USE AND MAINTENANCE

3.1 REMOTE CONTROL

All the air-conditioners functions are controlled, set or adjusted through the infrared remote control.

IMPORTANT : you cannot operate the unit without the remote control, so please ensure you replace the remote after use in the provided holder. If the remote control is misplaced or broken, please contact your Retailer or After Sales Service to purchase a new one.

FITTING AND CHANGING THE BATTERY

- Slide off the cover on the front of the remote to reveal the battery compartment.
- Insert the battery (2 x AAA).
- Refit the battery cover.
- Important: if pressing ON/OFF button no icons are displayed, please install the battery in the correct position.
- The exhausted batteries must be disposed of responsibly.

3.2 REMOTE CONTROL FUNCTIONS

| ICON | FUNCTION |
|------|--------------------|
| | Auto mode |
| | Cooling mode |
| | Dehumidifying mode |
| | Heating mode |
| | Fan mode |
| | Time |
| | Fan speed |
| | Air direction |
| | Timer off |
| | Timer on |
| | Sleeping mode |
| | Temperature |



To operate the unit, direct the remote control towards the unit.

3.3 INSTRUCTION FOR USE WITH REMOTE CONTROL

Switch on the remote control using the pink button in the centre of the remote control.

Firstly set the time by gently depressing the timer set button in the bottom right hand corner just above the battery compartment, then adjust the time by using ▼ button to adjust the minutes and ▲ button to adjust the hours.

Once this has been done, press the MODE button to select the required function:
 - Cooling - Dehumidification - Fan only - Heating - Auto.



When the mode is selected, adjust the temperature setting to your comfort: these temperatures are dependent on your individual requirement and can be adjusted while the unit is running.

In Auto mode the temperature settings are not adjustable (see paragraph 3.9)

Slide the front panel downwards to display further buttons.
 Timer on - Timer off - Fan speed x 3 - Sleep - Louvers.

Please refer to the following sections

3.4 COOLING FUNCTION

- Press the MODE button until the cooling mode is set. ❄️

- Press the ▼ and ▲ buttons to set the required room temperature.

When you set the temperature in cooling mode, the LCD on the front of the unit shows the set point, then after a few second the LCD display will then revert to room temperature and will decrease by 1 degree C in turn until the unit reaches your desired temperature.

- Press the (🌀) button and select the fan speed to high (🌀), middle (🌀), low (🌀) or auto.

(If AUTO is chosen, the fan speed is automatically adjusted to keep it as high as needed to reach the set temperature).

3.5 SLEEPING FUNCTION

- Press the MODE button to find cooling ❄️ /heating 🔥 /auto ⚠️ .

- Press the ▼ and ▲ buttons to set the required room temperature (not possible in AUTO function).

- Press the (🌙) button : when this icon is displayed, the fan speed is automatically set at the lowest level.

- Press again (🌙) to cancel this function setting.

3.6 HEATING FUNCTION

- Press the MODE button until the heating mode is set 🔥 .

- Press the ▼ and ▲ buttons to set the required room temperature.

- Press the (🌀) button and select the fan speed to high (🌀), middle (🌀), low (🌀) or auto.

(If AUTO is chosen, the fan speed is automatically adjusted to keep it as high as needed to reach the setting temperature).

When the equipment first turns onto heating mode, there will be a short delay of three or so minutes, this is a normal time delay function and the equipment will start heating after this short period of time.

When you set the temperature in heating mode, the LCD on the front of the unit shows the set point, then after a few second the LCD will then revert to room temperature and will rise by 1 degree C in turn until the unit reaches your desired temperature.

3.7 DEHUMIDIFYING FUNCTION

- Press the MODE button until the dehumidifying mode is set 💧 .

- The fan speed is automatically set.

3.8 FAN FUNCTION

- Press the MODE button until the fan mode is set. ✚

- Press the (🌀) button and select the fan speed to high (🌀), middle (🌀), low (🌀) or auto.

3.9 AUTO MODE

- Press the MODE button until the AUTO mode is set. ⚠️

In this mode the air conditioner will attempt to maintain the room temperature between 20°C and 25°C.

If the room temperature is below 20°C it will be in heating mode, if it rises above 25°C the unit will be in cooling mode, if it is between the two the air conditioner will simply circulate room temperature air.

The reason for the 5°C 'gap' is to stop the compressor oscillating rapidly between heating and cooling as this would severely shorten the life of the product should it be allowed to happen.

3.10 TIMER FUNCTION

AUTOMATIC SWITCHING OFF

- Press the MODE button and set the desired function.

- Press the buttons ▼ and ▲ to set the required room temperature.

- Press the (🌀) button and select the fan speed among high (🌀) middle (🌀), low (🌀) or auto.

(In case AUTO is chosen, the fan speed is automatically adjusted to keep it as high as needed to reach the setting temperature).

- Press the (🕒) button and adjust the switching off time pressing the button ▼(hours) and ▲(minutes).

- To confirm the setting, press again (🕒).

- Once the time is over, the unit will switch off automatically.

The setting will be cancelled if the button (🕒) is pressed again.

AUTOMATIC SWITCHING ON

- With the unit switched on, select the desired function by pressing the MODE button.
 - Switch off the unit.
 - Press the ⏸ button.
 - Set up the switching time pressing the buttons ▼ (hours) and ▲ (minutes).
 - To confirm the operation, press again the ⏸ button.
- The unit will start to work automatically according to the selected time.
- To cancel the setting, press again the ⏸ button.

3.11 MAINTENANCE

INTERNAL UNIT MAINTENANCE

FILTERS CLEANING:

The filters should be regularly cleaned to keep the unit running efficiently. Clean the filters every two weeks.

How to proceed:

- Disconnect the unit from the electrical supply.
- Extract the filter grating.

As the filter has three different compositions, the cleaning operations should be done as follows:

- Extract the filters B/C from their case.
- Clean the B / C filters only with a vacuum cleaner, being careful not to damage them.
- Clean the A filter by washing it with warm water (max 40°C) and mild detergent.
- Rinse it with water only and let it dry in a shadowy place (do not expose it to direct sun rays).
- When the filter is perfectly dry, insert it back together with the other filters in their original position.
- Insert the grating above the unit until it is perfectly positioned.
- It is advisable to change the B / C filters annually. Should you need filters replacements, call your Retailer or contact your After Sales Service.

ATTENTION: Do not use the air conditioner without filters as it could seriously damage the unit.

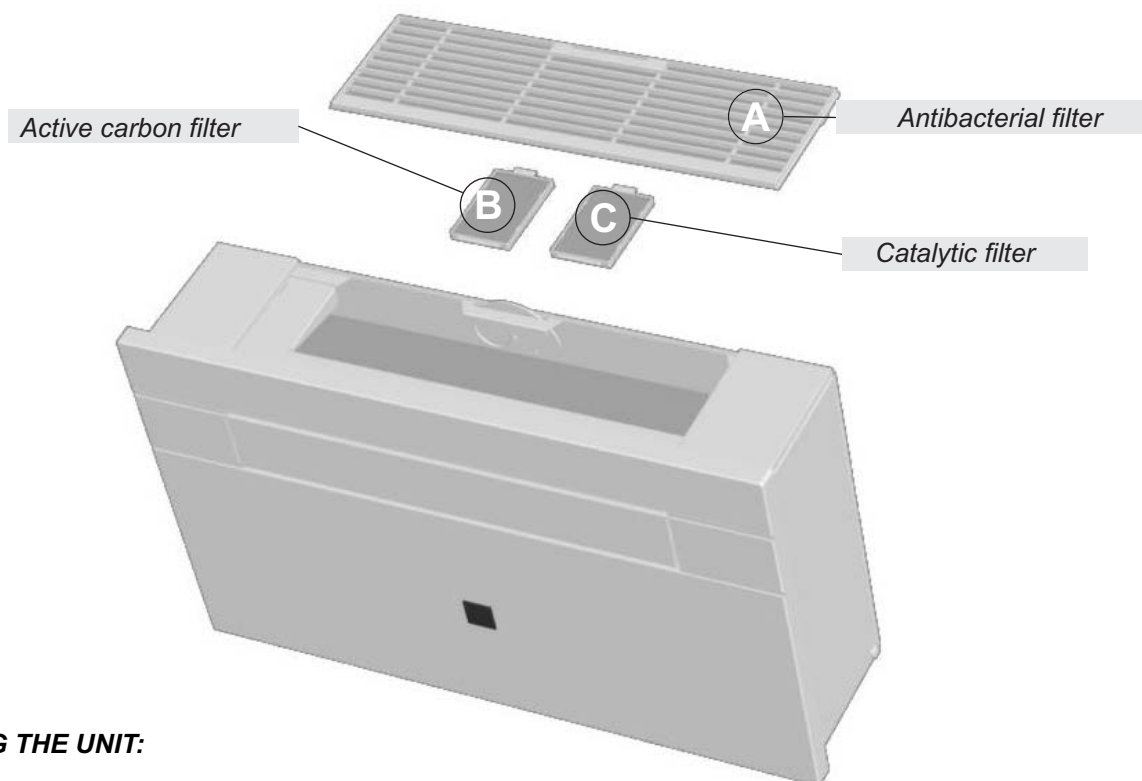

CLEANING THE UNIT:

- Disconnect the unit from the electrical supply.
- Wipe external surfaces clean with a damp cloth only.
- Do not use an abrasive cloth and/ or solvents, as this may damage the surfaces.
- Do not use excessively wet cloths or sponges, as water stagnation could damage the unit and compromise safety.

3.12 PROBLEM SOLVING

| PROBLEM | POSSIBLE CAUSE / REMEDIES |
|--|---|
| <i>The air-conditioner does not work.</i> | <ul style="list-style-type: none">- <i>Wrong setting of the timer / Check it.</i>- <i>Problems on the power supply/Verify the Presence of voltage.</i> |
| <i>The air-conditioner does not refrigerate the room</i> | <ul style="list-style-type: none">- <i>The filter could be dirty / Clean it.</i>- <i>The room temperature is too high / Wait until the temperature goes down.</i>- <i>The temperature is not properly set / Check it.</i> |
| <i>Strange smell in the room.</i> | <ul style="list-style-type: none">- <i>The grids could be obstructed / Check and remove the eventual obstacles.</i>- <i>Dampness in the room, coming from walls, carpets, furnishing or similar</i> |
| <i>Water drips from the air-conditioner.</i> | <ul style="list-style-type: none">- <i>Wrong installation of the air-conditioner.</i>- <i>Wrong connection of the drainage pipe.</i> |
| <i>The remote control does not work.</i> | <ul style="list-style-type: none">- <i>Exhausted batteries.</i>- <i>Wrong insertion of the batteries inside the remote control</i> |
| <i>The air-conditioner does not work for 3 minutes when switched on.</i> | <ul style="list-style-type: none">- <i>Protection of the air-conditioner. Wait for 3 minutes and the air-conditioner will start to work again.</i> |